

# ULC-S652 Approved Waste Oil Tanks

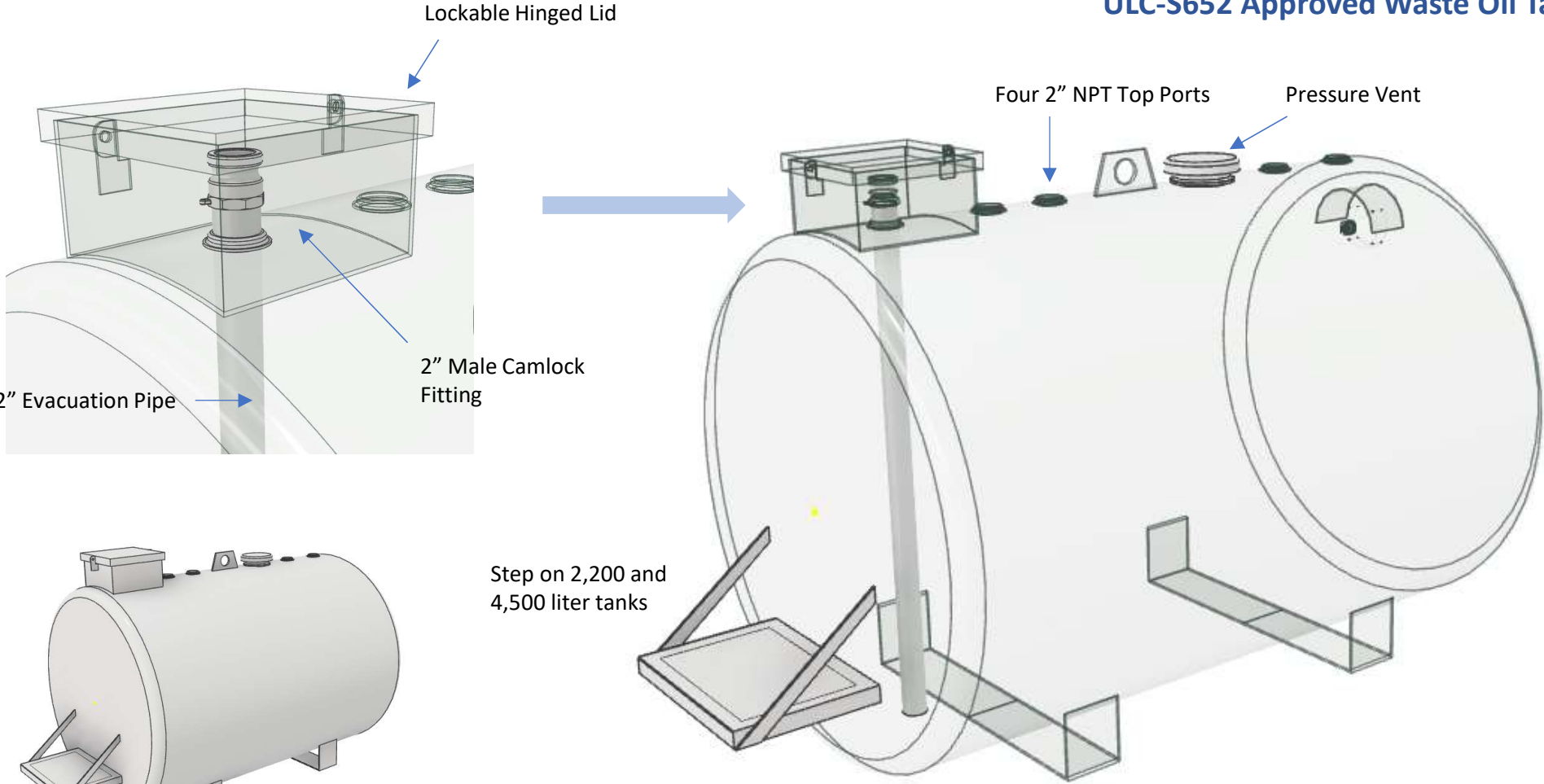

Step on 2,200 and 4,500 liter tanks

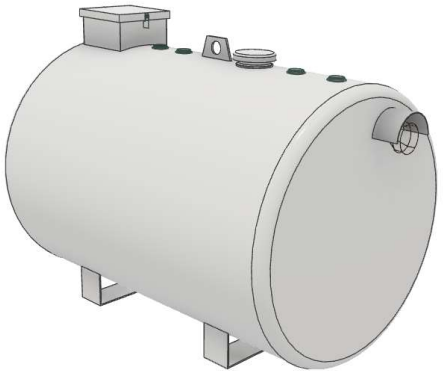
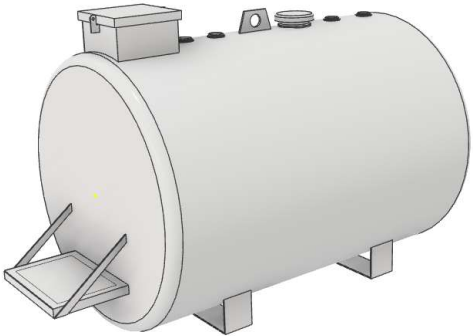

Vacuum Monitor For interstitial space.

Tank Capacity	Diameter	Length	Weight (LBS)
450 L (100 Gal)	30"	48"	200
1,100 L (250 Gal)	38"	60"	500
1,360 L (300 Gal)	38"	72"	600
2,200 L (500 Gal)	50"	72"	1,000
4,500 L (1,000 Gal)	50"	144"	2,000