

WOP-FL-16NHH Waste Oil Evacuation System

Basic waste oil evacuation pump package for
Fast Lube Operations with Pit Type Waste Oil Receivers

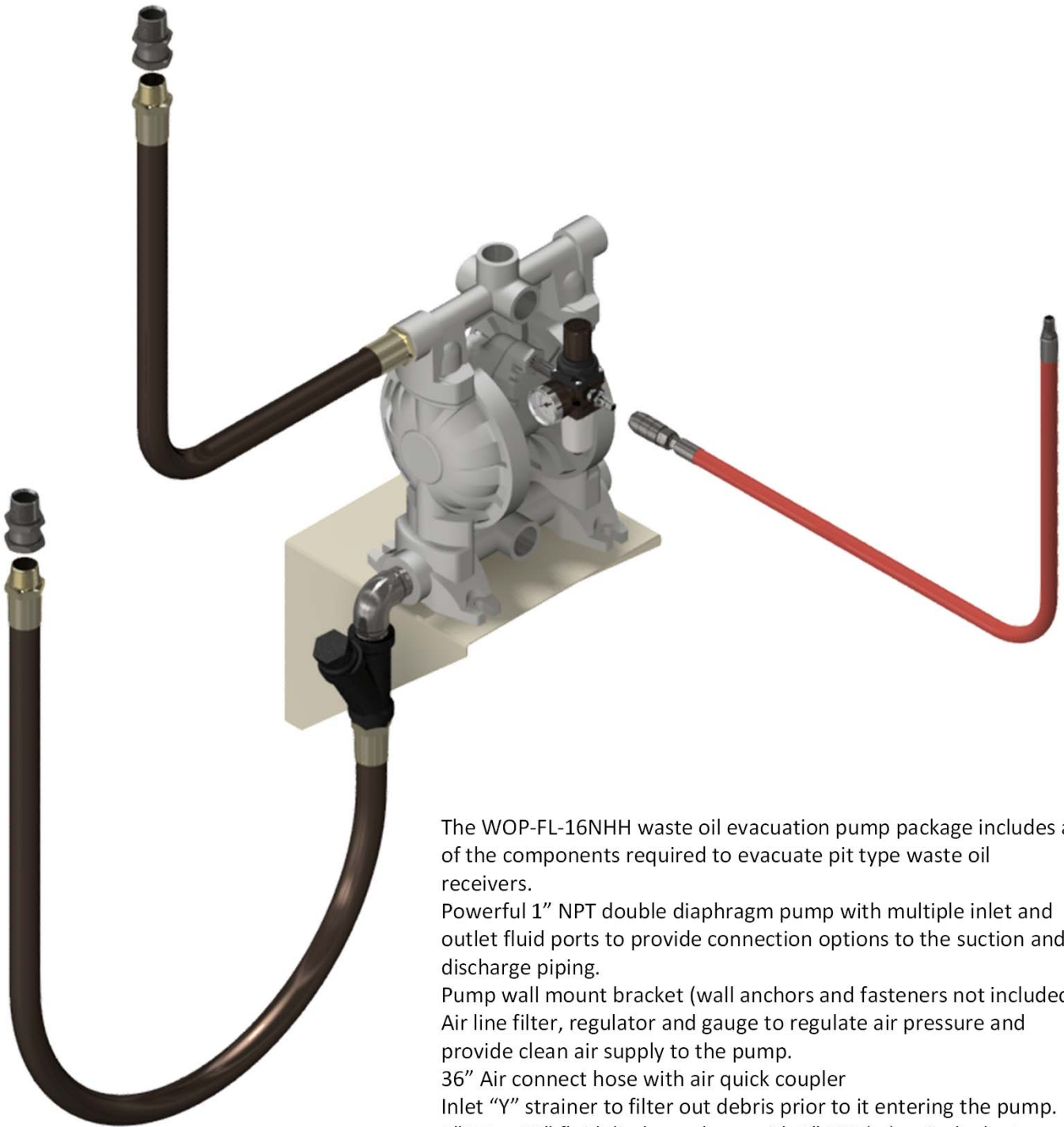

The WOP-FL-16NHH waste oil evacuation pump package includes all of the components required to evacuate pit type waste oil receivers.

Powerful 1" NPT double diaphragm pump with multiple inlet and outlet fluid ports to provide connection options to the suction and discharge piping.

Pump wall mount bracket (wall anchors and fasteners not included)

Air line filter, regulator and gauge to regulate air pressure and provide clean air supply to the pump.

36" Air connect hose with air quick coupler

Inlet "Y" strainer to filter out debris prior to it entering the pump.

1" I.D. x 36" fluid discharge hose with 1" NPT(m) swivel adapter



1" I.D. x 60" fluid discharge hose with 1" NPT(m) swivel adapter

WOP-FL-16NHH Waste Oil Evacuation System

Multi-Port Diaphragm Pump

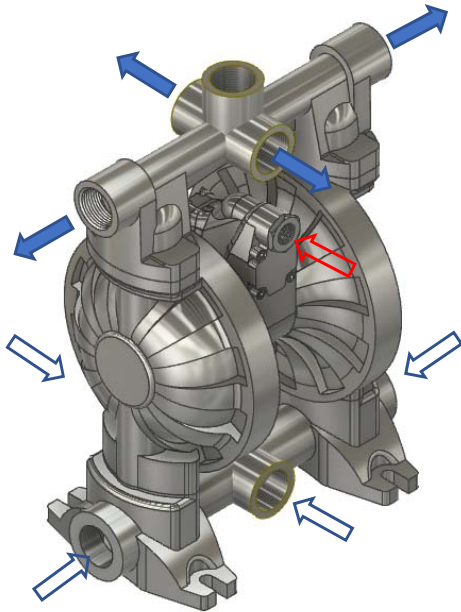
Part Number RA-3CC-26111NHH-55



-  Fluid Inlet 1" NPT(f)
-  Fluid Outlet 1" NPT(f)
-  Air Inlet 3/8" NPT(f)

Multiple inlets and outlets provide for the best connection depending on the requirements of the installation.

Pump comes with 1" NPT(m) plugs for unused ports.

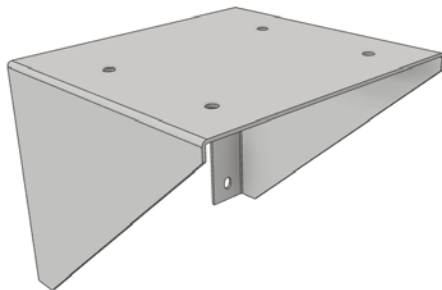

RA-33591-55 Pump Wall Mount Bracket

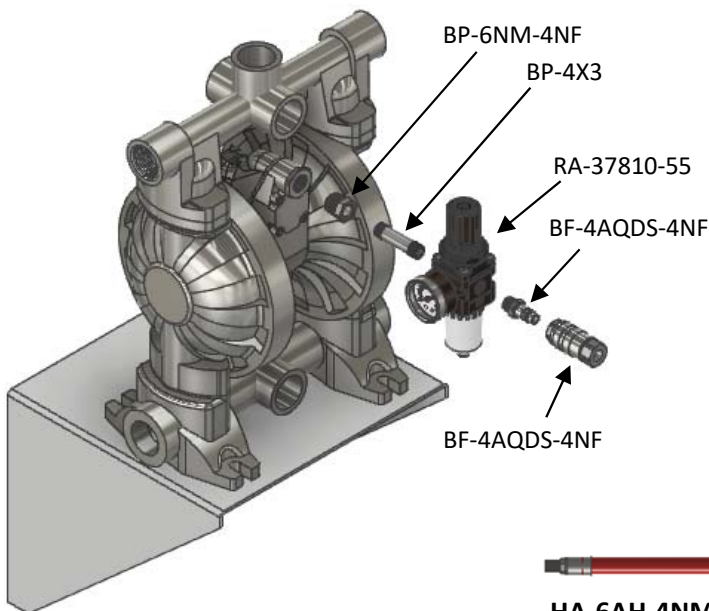

Air Control Parts

- BP-6NM-4NF 3/8" NPT(m) X 1/4" NPT(f) Bushing
- BP-4X3 1/4" X 3" Pipe Nipple
- RA-37810-55 Air Filter, Regulator & Gauge
- SF-4AQDP-4NF 1/4" NPT(m) Quick Coupler Nipple
- BF-4AQDS-4NF 1/4" NPT(f) Quick Coupler Socket

Air Connect Hose Assembly



- HA-6AH-4NM-4NM-36 3 Ft. Air Connect hose
- 1/4" NPT(m) Both Ends

