



PRO/MARK INDUSTRIALS

Div. of R.D. Lewis Sales Limited

P.O. Box 1504, Woodstock, ON N4S 0A7

Phone: (519) 658-3204

E-Mail: sales@promarkindustrials.ca

www.promarkindustrials.ca



THE MiniMIZER![®]

ELEGANT IN DESIGN

Dispense Fluids in A Low Volume, Low Pressure, Precision Spray.

- **Minimize the Over-Spray**
- **Minimize the Cleanup in the Work Area**
- **Minimize Airborne Droplets of Fluids in the Air**
- **Minimize Labor by Automating Dispensing of Fluids**
- **Minimize the Amount of Fluids Used to Manufacture a Part**
- **Minimize the Cleanup of Parts after Manufacturing is Completed**

Dispense Fluids in a Controlled Fine Spray.

The MinaMizer is aptly named because it minimizes the amount of air and fluid used in fine spray applications. It is common sense to use equipment sophisticated enough to dispense the least amount of fluid necessary to accomplish the right amount of coverage for a particular application. Using excess fluid accomplishes nothing except increasing material cost, part cleanup cost and machine cleanup cost. The MinaMizer uses precision air and fluid regulators that hold true to their settings to maintain the fluid and air pressures being dispensed out the nozzles. Precision Needle valves control the volume of fluid being dispensed out of the nozzle. A variety of

controls, both manual and computer controlled are offered to allow for individual preferences in setting up an installation. The design of the MinaMizer Nozzle allows for an even, consistent, low pressure, low volume spray pattern. When the MinaMizer is activated a low pressure air assist allows the fluid to be dispensed in a light coating from a single or multiple nozzles. The low pressure breaks the fluid to be dispensed in a light coating from a single or multiple nozzles. All the nozzles, (up to six) work in unison to cover large or small areas with an even coating. Nozzles can dispense fluid continuously or in an On/Off mode as directed by a LSP Electronic Controller.

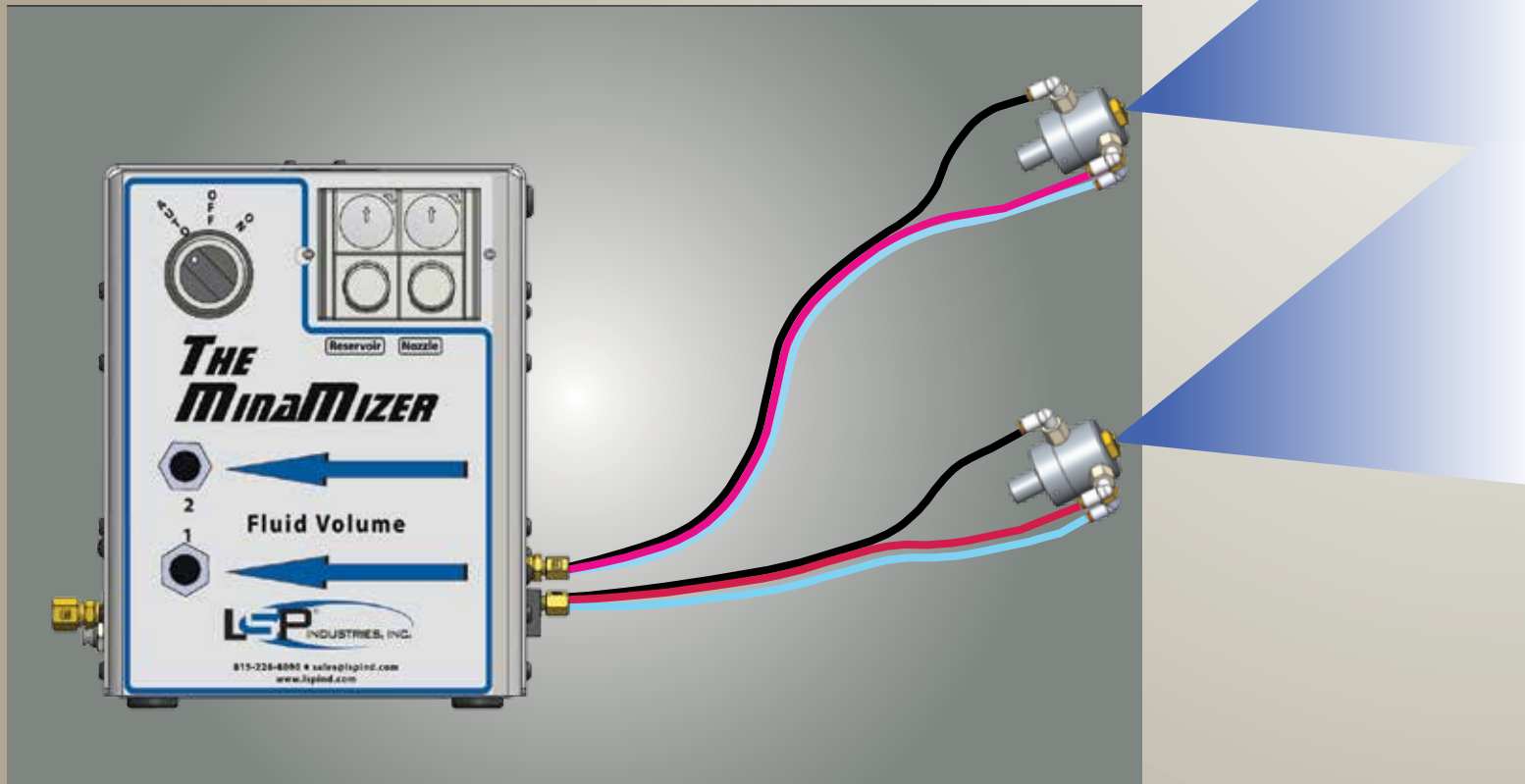

Available in a variety of configurations to fit the different applications. Made to fit the job no matter the size or the type of application.

The Basic MinaMizer with Solenoid Valve for automatic remote control, choice of Nozzles and 10' of Tubing to the Nozzles.

Normal actuation is either the On/Off positions on the Three Position Valve or the automatic position to operate from remote control. Other Actuating Systems & other accessories are ordered separately.



- MZ1002 W/2 Nozzles of Choice
- MZ1004 W/4 Nozzles of Choice
- MZ1006 W/6 Nozzles of Choice

The Basic MinaMizer with Solenoid Valve for automatic remote control, Reservoir, choice of Nozzles and 10' of Tubing to the Nozzles.

Normal actuation is either the On/Off positions on the Three Position Valve or the automatic position to operate from remote control. Other Actuating Systems & other accessories are ordered separately.

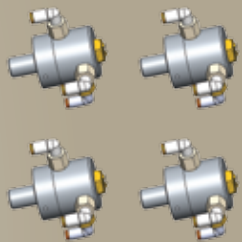

- MZ1012 W/2 Nozzles of Choice
- MZ1014 W/4 Nozzles of Choice
- MZ1016 W/6 Nozzles of Choice

The Basic MinaMizer with The FC400 Electronic Controller, Solenoid Valve for automatic remote control, Reservoir, choice of Nozzles and 10' of Tubing to the Nozzles.

Normal actuation uses the Three Position Valve. ON in for manual On/Off and the Automatic Position is to operate the MinaMizer when the sensor receives a signal. The FC400 Controller is programmed to automatically control the MinaMizer. See back cover for features of the FC400. Other Actuating Systems & other accessories are available separately.

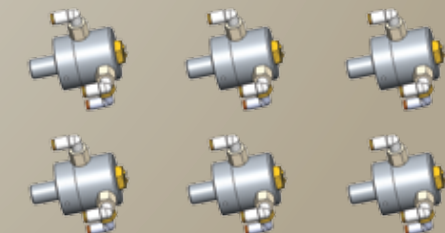

- MZ1022 W/2 Nozzles of Choice
- MZ1024 W/4 Nozzles of Choice
- MZ1026 W/6 Nozzles of Choice

Here's How the *MinaMIZER* Works!

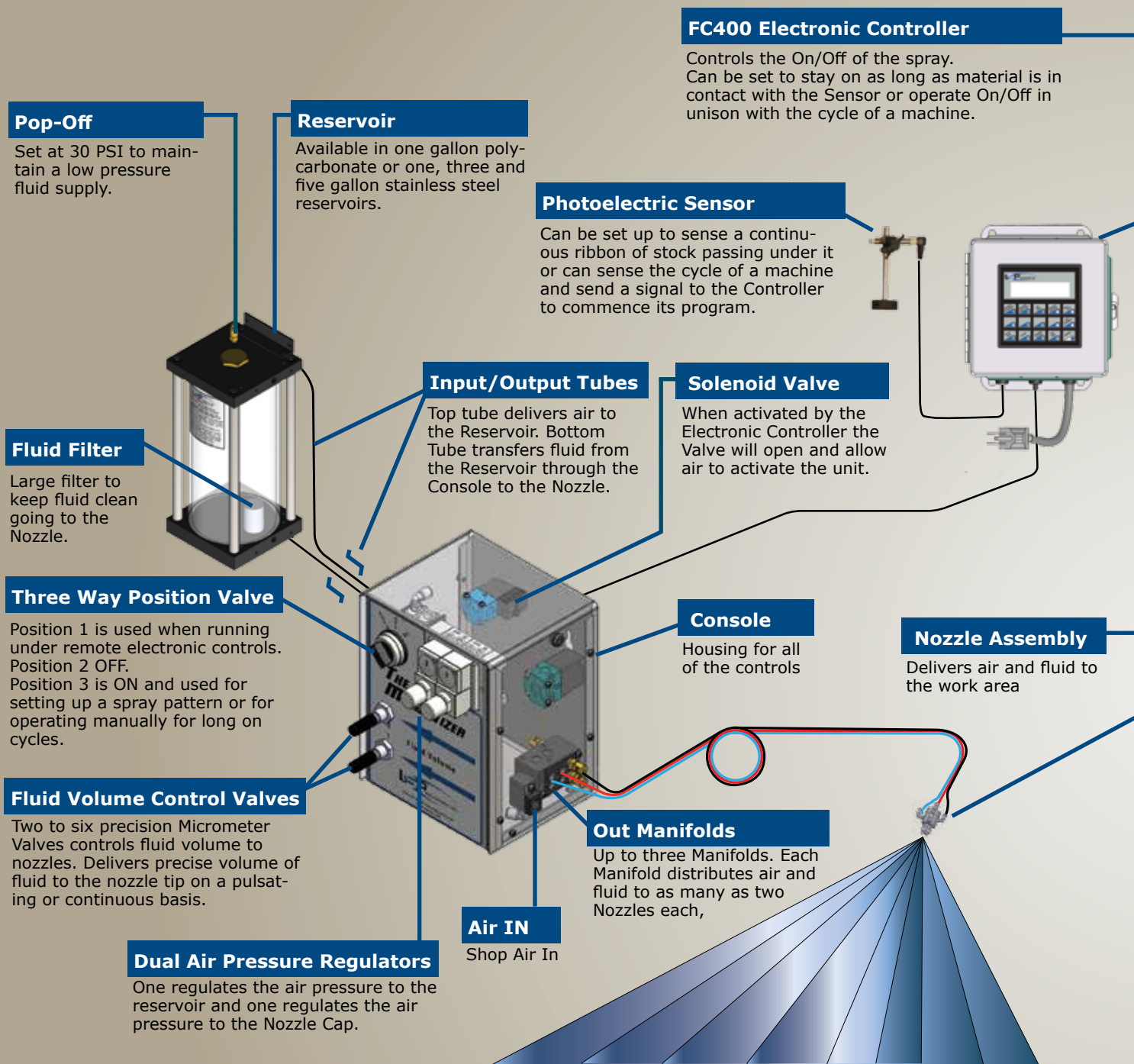

The MinaMizer dispenses fluid in a controlled, low volume, low velocity spray, consistently and in a steady dispersion. The MinaMizer consists of the Control Cabinet, pressurized Reservoir and precision Nozzle Assemblies.

It can be operated manually with the Three Way Valve. When turned to the ON position adjustments can be made to get the correct spray pattern.

Once spray pattern has been determined the Controller can be set to automatic. The photoelectric sensor can be positioned to sense when stock begins and ends running through a machine. The Controller will then tell the MinaMizer when to start and stop dispensing fluid. The Controller can also be used to sense cycles of a machine.

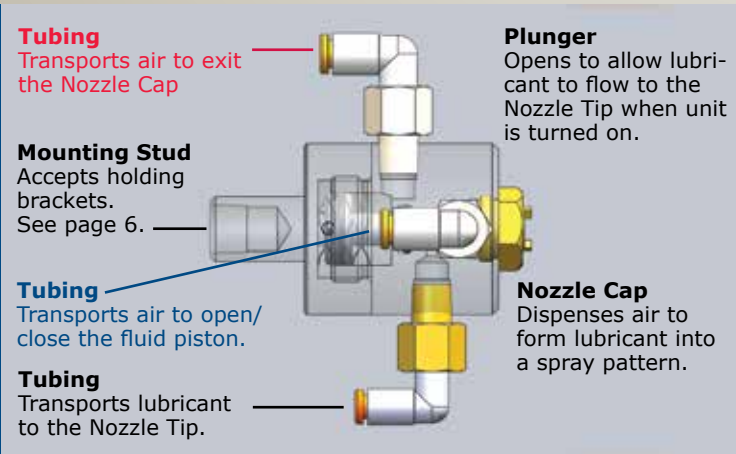

The *MinaMIZER* Applications

Use the MinaMizer to dispense small amounts of lubricant. Here are a few examples.

Stamping Application

A little lubrication goes a long way in a stamping application. The MinaMizer can be tied into the cycle of the press or allowed to run continuously during the stamping operation. The low volume, low velocity used to dispense the lubricant helps keep the lubricant on the stock where it is needed.

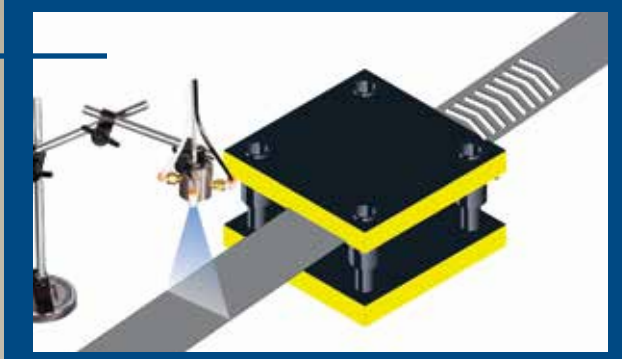

Slat Conveyor Application

For the applications on slat conveyors where the slats themselves have to be lubricated the MinaMizer is a perfect dispenser for the application. Used either on a timed basis or left on continuously. Properly lubricated slats prevent bottles or other parts from shattering.



Robot Controlled Application

On assemblies where there are multiple locations that need spot lubrication, a robot is the ideal means of dispensing the lubricant to the various spots. Mount the MinaMizer nozzle to the arm of the robot and then program the MinaMizer to dispense lubricant when the nozzle is in the designated spot.



Bakery Pan Application

Bakery pans used in high production baking facilities have to be lubricated with a light, even coating of cooking oil to ensure the clean separation of the baked part from the pan without any burnt spots on the bottom. Too much oil or an uneven coating can be detrimental to the finished product.

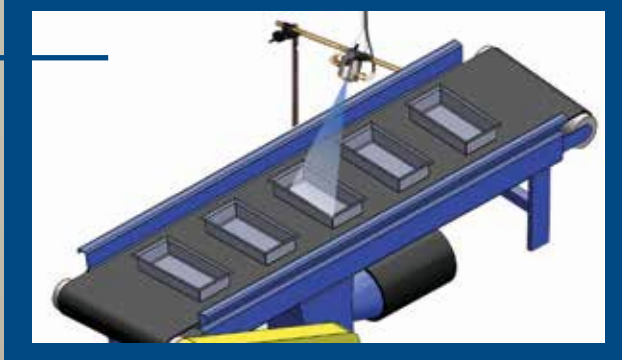

Assembly Application

Automatic assembly machines have many applications where parts that will be rubbing against each other or parts being inserted into housings. In most cases these parts should be lubricated to prevent galling or nicking during the assembly.

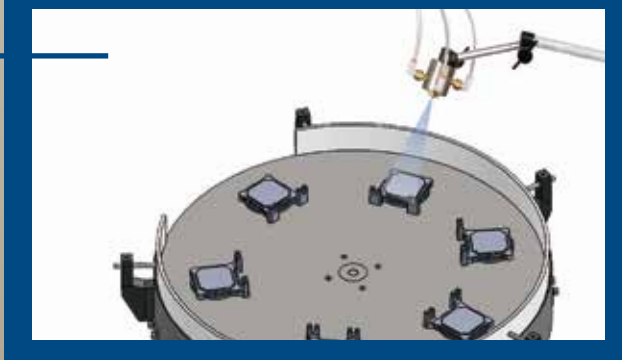

The *MinaMIZER* Nozzles

Complete Nozzle Assemblies

MZ2011 Up to 95° Fan, depending on viscosity of lubricant
 MZ2015 Up to 55° Round

Fluid Dispensing Nozzles

One Nozzle Assembly that accepts either a round spray pattern tip or fan shaped spray nozzle tip.

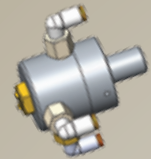

MZ2011
95 degree
Fan Nozzle

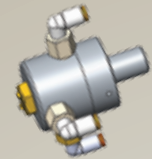

MZ2015
55 degree
Round Nozzle

The *MinaMIZER* Nozzle Holders

Five standard nozzle holders designed to cover most applications where intricate positioning of the nozzle is needed. Nozzle holders are designed to allow maximum manipulation of the spray nozzle. Special nozzle holders can be configured upon request.



MZ9001
A 12"rod attached on a magnet. One MZ9010, one MZ9011 and a 3/8" X 10" rod.



MZ9002
A 12"rod attached on a magnet. One MZ9010, two MZ9011 and two 3/8" X 10" rods.

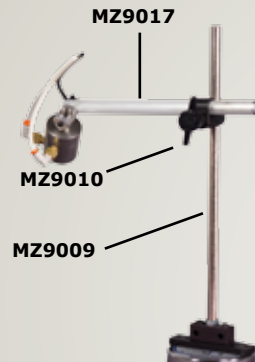

MZ9003
A 12"rod attached on a magnet. A MZ9010 and a MZ9017.



MZ9004
Two 12"rods attached on magnets. Two MZ9010 and two MZ9011. Cross rod Not included with this package.



MZ9005
A 12"rod attached on a magnet. One MZ9010, and one 12" rod to screw into the back stud on the back of the nozzle.

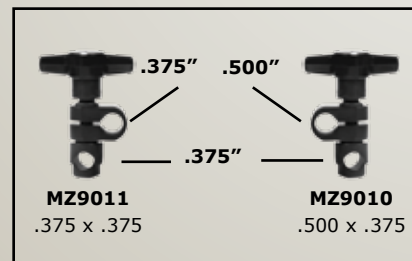

Swivel Brackets

Allows nozzles to be mounted on rods and swivel up to 360 degrees. There are two Swivel Brackets to allow for different types of installations. Some Nozzle Holders will use both Swivel Brackets.

MZ9400 Tri-Tubes

Replacement tubes for nozzle assemblies. Three different colored tubes, welded together for ease of installation.



The *MinaMIZER* Dimensions

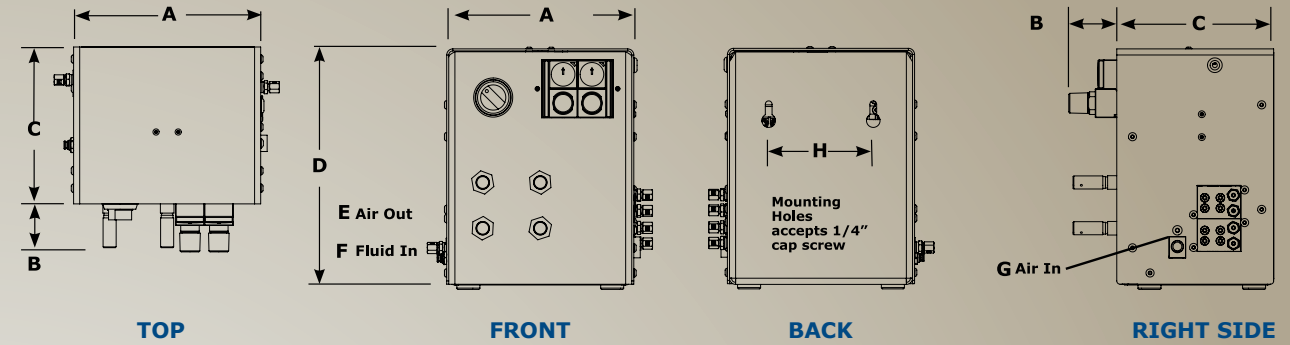

MinaMizer Console only - Nozzles not shown

	A	B	C	D	E	F	G	H	I	J	K
MZ1002	6.218	2.000	6.000	9.000	5/32	5/32	1/8 NPTF	4.00	5/32	5/32	5/32
MZ 1004	6.218	2.000	6.000	9.000	5/32	5/32	1/8 NPTF	4.00	5/32	5/32	5/32
MZ1006	6.218	2.000	6.000	9.000	5/32	5/32	1/8 NPTF	4.00	5/32	5/32	5/32

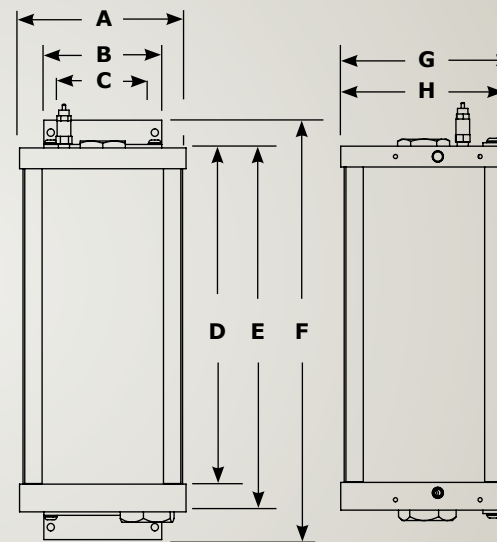

Reservoir - One Gallon

	A	B	C	D	E	F	G	H
MZ3050	6.000	4.250	3.750	11.350	13.100	15.100	6.100	6.000

Reservoirs - Stainless Steel

	Volume	A	B	C	D	E	F
MZ3051	1 Gal.	9.000	8.380	1/4 NPTF	1/4 NPTF	1/4 NPTF	1/4 NPTF
MZ3053	3 Gal.	9.000	15.120	1/4 NPTF	1/4 NPTF	1/4 NPTF	1/4 NPTF
MZ3055	5 Gal.	9.000	22.380	1/4 NPTF	1/4 NPTF	1/4 NPTF	1/4 NPTF

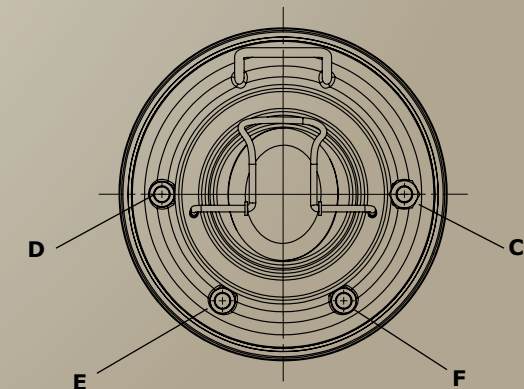
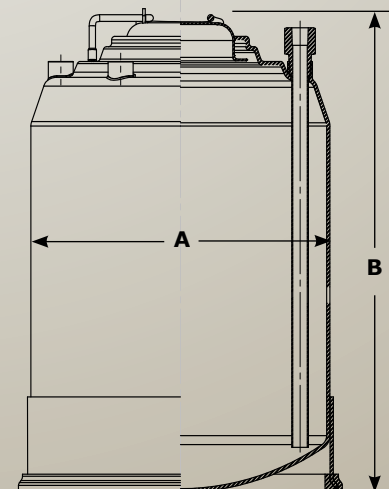

Accessories for the *MinaMizer*



MZ9020 - MinaMizer Stand

A stable stand, five feet tall to hold the MinaMizer, reservoir and LSP Controller. Convenient for easy operation and easy to move from location to location.



Stainless Steel Pressure Pots

For use with the bigger jobs. Includes: Pressure Gauge, Filter and 5 feet of Distribution Tubing to MinaMizer

1 Gal.	MZ3051
3 Gal.	MZ3053
5 Gal.	MZ3055

The FC400 Controller to activate the MinaMizer

The FC400 is used when MinaMizer must go on and off with the cycle of a machine. It can pulsate with cycles or skip cycles.



The FC400 Electronic Controller (at left)

The ultimate MinaMizer Controller offers three individual controls, a Time Delay, a Pulsator and a Counter.

1. Time Delay: Controls when the MinaMizer dispenses fluid after it receives a signal from the Proximity Sensor.
2. Pulsator: Program to deliver multiple sprays of fluid on each cycle.
3. Counter: Set the controller to dispense fluid on a set count.
4. Continuous ON time when needed

PRO/MARK INDUSTRIALS

Div. of R.D. Lewis Sales Limited

P.O. Box 1504, Woodstock, ON N4S 0A7

Phone: (519) 658-3204

E-Mail: sales@promarkindustrials.ca

www.promarkindustrials.ca

P. O. Box 5303 (61125)

5060 27th Ave. (61109)

Rockford, IL

Tel: 815-226-8090 Fax : 815-226-9250 email: sales@lspind.com

www.lspind.com

