

Medium Viscosity Piston Tank — for up to NLGI 2 Grease

Piston Follower Operation

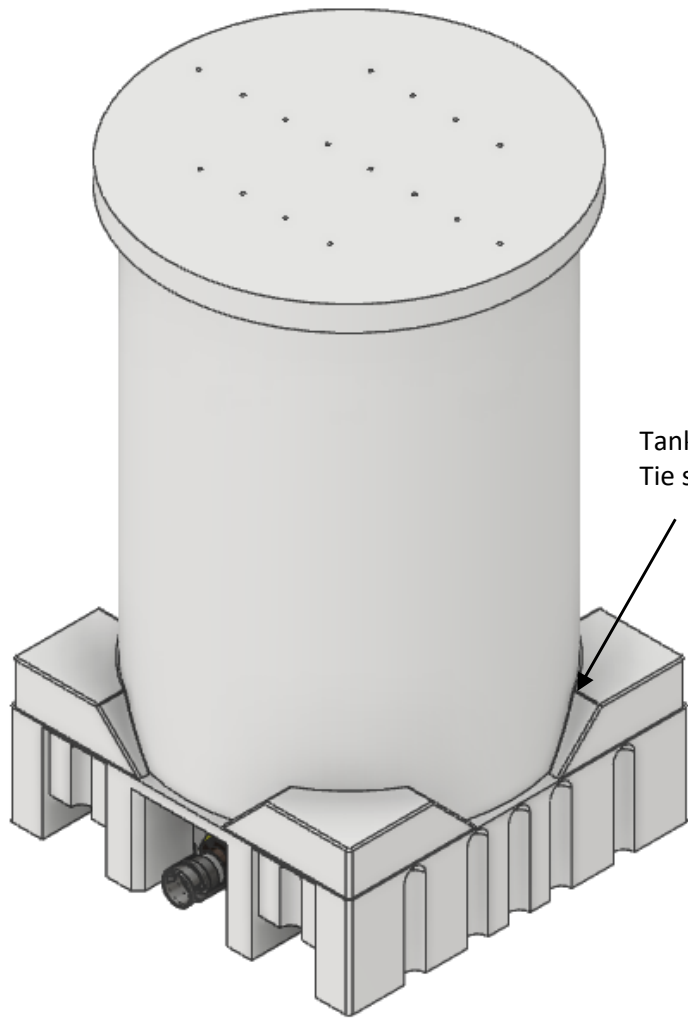

Tank is welded to the base.
Tie straps not required.

Removeable Top. →

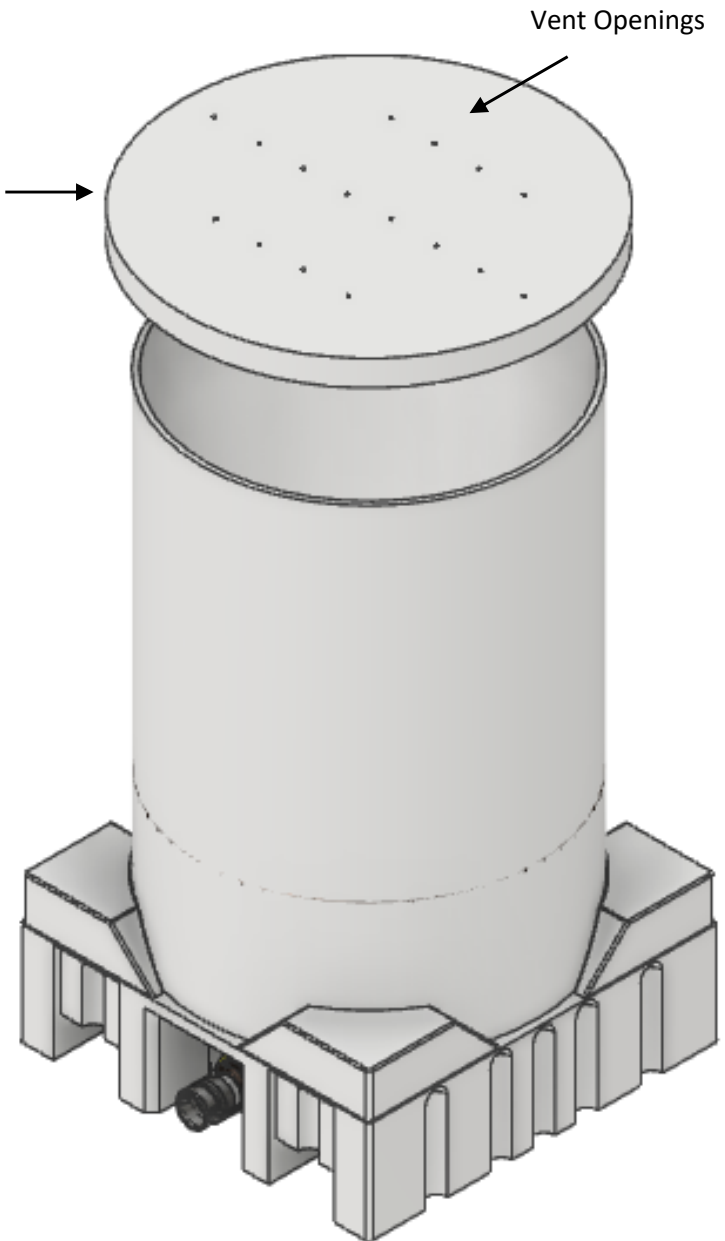

Vent Openings

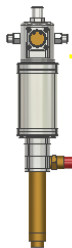

PRO/MARK INDUSTRIALS

Div. R.D. Lewis Sales Limited

Lubrication - Fluid Storage, Handling, Dispensing

PISTON FOLLOWER OPERATION

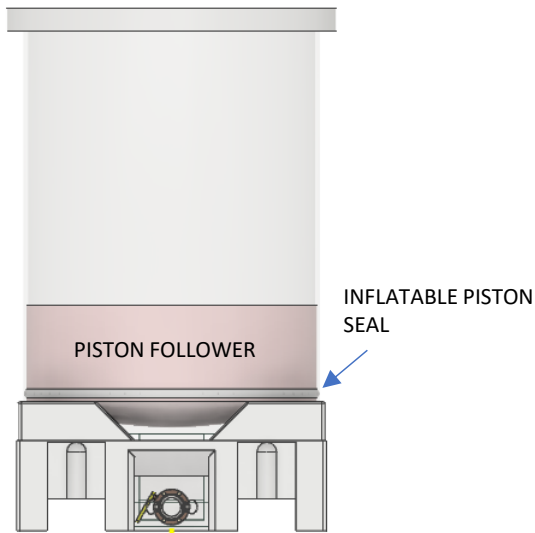

THE RED FOLLOWER IS VISIBLE THROUGH THE WALL OF THE TANK SO THE OPERATOR CAN SEE WHEN THE TANK IS FULL. HIGH LEVEL WARNINGS AND/OR AUTOMATED SHUT OFFS CAN BE INSTALLED TO FURTHER PREVENT OVERFILLING.

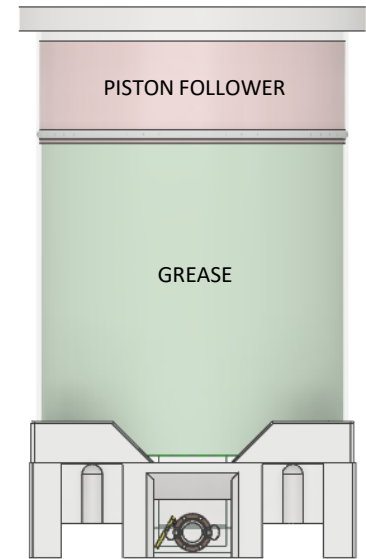

AIR ENTERS THROUGH THE VENT OPENINGS IN THE LID AS THE TANK IS BEING EVACUATED

GREASE IS PUMPED INTO THE TANK

